

GUIDANCE: SAFETY HARNESS INSTALLATION

Motorsport UK has committed to an in-depth review of competitor safety equipment. This review includes initiatives aimed to reduce the burden on competitors of the unnecessary replacement of safety equipment, while ensuring suitably high standards of safety are maintained in the sport.

As a result of this review, Motorsport UK will recognise an extended life for certain FIA-homologated harnesses. In any discipline where An FIA-homologated harness is a regulatory requirement, harnesses homologated to the FIA 8853-2016 standard are granted a five-year extension at the end of their initial five-year life.

A cornerstone of this initiative is to provide greater education for competitors in respect of their own safety and to place more responsibility on the competitor to maintain a level of safety equipment, above a defined Motorsport UK minimum standard.

How will this affect my harness?

Firstly, you will need to check what FIA standard your harness is homologated to. The harness standard will be detailed on the homologation label, such as in the example shown here. Motorsport UK will only recognise an extended life for harnesses which display the FIA 8853-2016 standard on the label.



To determine the extended validity of an FIA 8853-2016 harness, you should add five years to the year shown on the label. For example, a label that shows a not valid after date of 2018 will be valid until 31 December 2023.

Installation

The harness is one of the most critical safety systems within any vehicle, therefore it is vital that it is mounted correctly. Motorsport UK regulations give a specification for mounting the harness in the Motorsport UK Yearbook – see K2.1 to K2.1.11. Harnesses may also be installed as per FIA regulations, which are found in FIA Appendix J Article 253: Art.6. The original manufacturer's mounting points may be used if they are in a suitable location. Alternatively, new mounting points may be created in the vehicle chassis using the methods shown in the diagrams below.

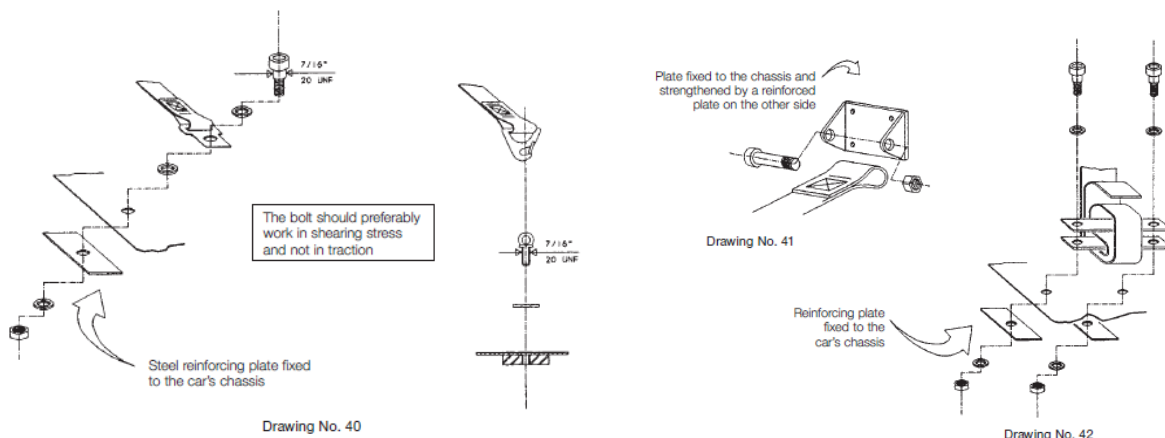

FIA regulations state that where new mounting points in the chassis are created they should each be reinforced with steel counter plates of an area no less than 40cm² and 3mm thickness. The diagrams above show the location of these counter plates. Bolts used for mounting a harness must be a minimum of 7/16in UNF or M12 8.8.

Harnesses shoulder straps may also be fixed to a harness bar which forms part of the vehicle ROPS; the straps may either be looped around the harness bar or bolted to the bar. If bolted to the harness bar, an insert must be welded for each mounting point as shown in drawing on the right.

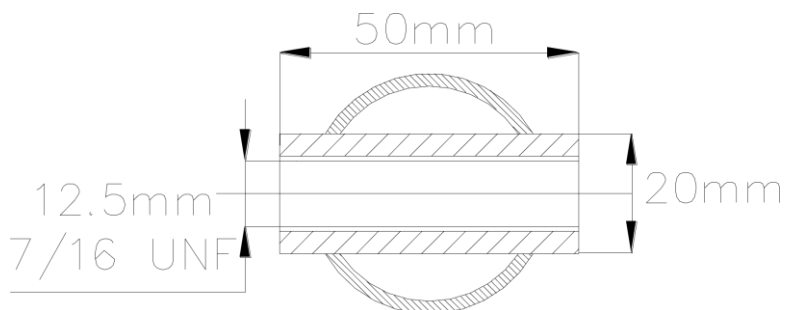

If looped around the harness bar, the straps should pass three times through the 3-bar slide and the strap end should protrude by at least 100mm. The 3-bar slide should be positioned as close as possible to the harness bar.

It is also important to consider the harness angle, especially where a Frontal Head Restraint (FHR) such as a HANS or Hybrid is being used.



Motorsport UK regulations require the shoulder straps to be a maximum of 45° below horizontal. However, for use with an FHR it is recommended that they are no more than 20° below horizontal and they must not be angled upwards at all. The diagram below shows the angle required for each element of the harness.

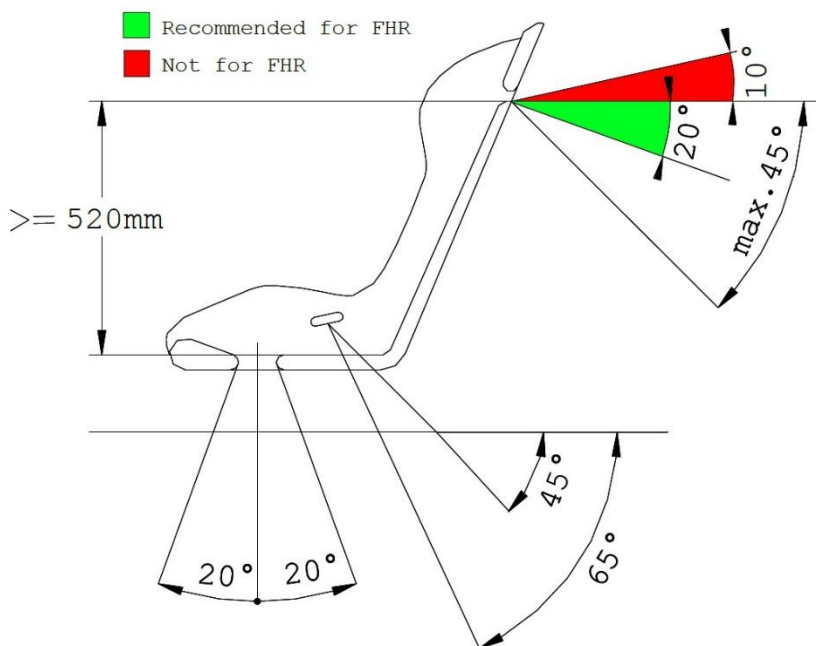

Harnesses should only be mounted in accordance with the manufacturer's instructions and Motorsport UK or FIA regulations. Do not modify the harness in any way, as this will invalidate the homologation. Small modifications such as attachments for an intercom may be permitted if installed as per FIA regulations; you should consult with the manufacturer before making any such changes.

Maintenance

With the extended validity of harness homologation, it is important that as a competitor you take responsibility for the care and maintenance of your equipment. If you have any doubts or concerns over the condition or installation of your harness, please consult the manufacturer.

Regular checks and maintenance should be performed throughout the life of the harness to ensure it remains in good condition. The harness should be checked regularly for damage, as it can be subjected to some extreme forces during regular use. Therefore, even if the vehicle has not been involved in any accidents, the harness could still suffer damage through the normal wear and tear of competition.

Harnesses should be replaced if any damage such as fraying or cuts in the webbing are found, or if the webbing has been exposed to oils, fuel, chemicals or excessive heat.

The harness attachment (the brackets that bolt the harness to the chassis) should be checked regularly for security, ensuring the bolts remain tightened to the manufacturer's recommended torque. They should also be checked visually for any cracking, distortion or corrosion. Pay particular attention to ensure the bolt holes have not become ovalised. The harness should be replaced if any metal parts or buckles are bent, deformed or corroded.

The mounting points on the bodyshell/chassis should also be checked regularly for any cracking or corrosion.

Accidents

If your vehicle is involved in an accident, it is important that you do not simply assume your harness will be fine to use again. Even what appears to be a minor impact can put huge loadings through harnesses and their mountings.

Following an accident your harness and its mounting should be carefully inspected for damage and ideally this inspection should be undertaken by the manufacturer. If there is damage to any component of the harness, that harness should be replaced. Please seek the manufacturer's advice before using any equipment that has been involved in an accident.

Conclusion

The effectiveness and longevity of a safety harness are directly related to the manner in which they are installed, used and maintained. A harness is not an 'install and forget' piece of equipment and it is your own responsibility to ensure it is installed and maintained correctly. Remember that no matter how good your harness is, it is only going to be effective if it is installed correctly.

If you have any questions over the use and installation of harnesses, please contact the Motorsport UK Technical team at technical@motorsportuk.org or on 01753 765000.